

Schottabdichtung • voll geteilte Ausführung • 50 – 600 mm
Bulkhead Seal • full split design • 50 – 600 mm



Technische Merkmale:

- Trockenlaufende Spaltdichtung
- Typ-Zulassung: DNV GL, ABS
- Einfache Montage durch geteilte Gehäuse und geteilte Dichtringe
- Elektrische Trennung zwischen Welle und Schott (keine Beeinflussung des Kathoden-Schutzsystems)
- Ausgelegt für hohe Gleitgeschwindigkeiten
- Radiale Beweglichkeit: +/- 5 mm
- Optional: Sperrgasanschluss

Einsatzgrenzen:

Wellendurchmesser:	50 bis 600 mm
Temperatur:	- 5° bis +70° C
Druck:	max. 3 bar
Gleitgeschwindigkeit:	max. 40 m/s

Technical Features:

- Dry running gap-seal
- Type-Approval: DNV GL, ABS
- Easy installation due to split housings and split seal rings
- Electrical Insulation between shaft and bulkhead (no interference with the cathodic protection system)
- Developed for high shaft speed
- Allowed radial shaft movement: +/- 5 mm
- Optional: Barrier gas connection

Operating Limits:

Shaft diameter:	50 to 600 mm
Temperature:	-5° to +70° C
Operating pressure:	max. 3 bar
Gliding speed:	max. 40 m/s

Bulkhead Seal 50 - 600 mm

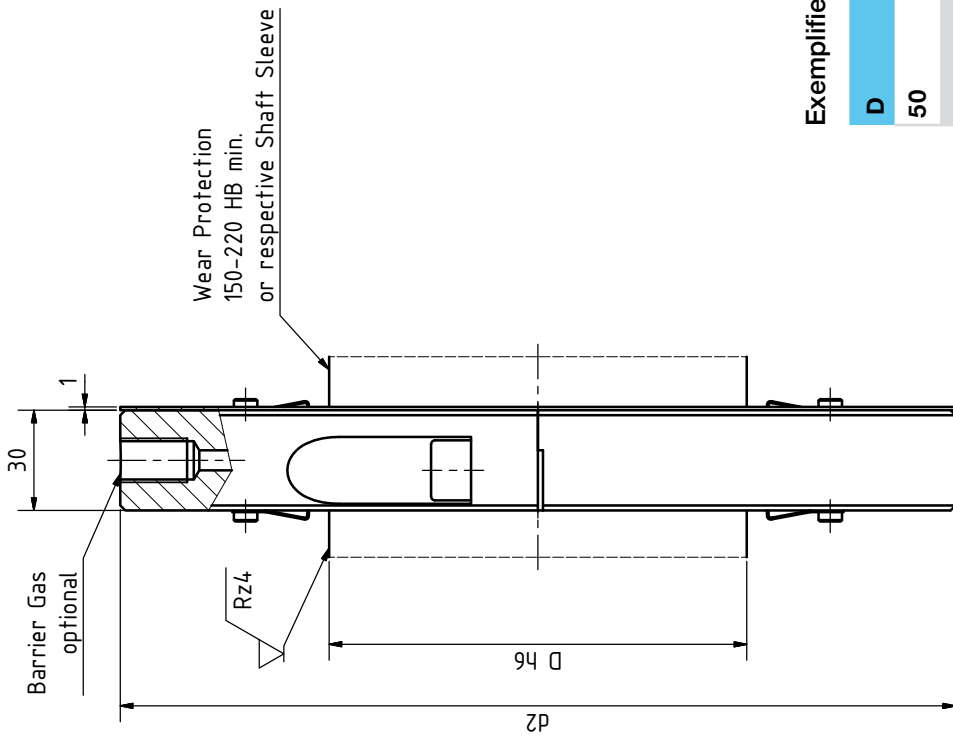
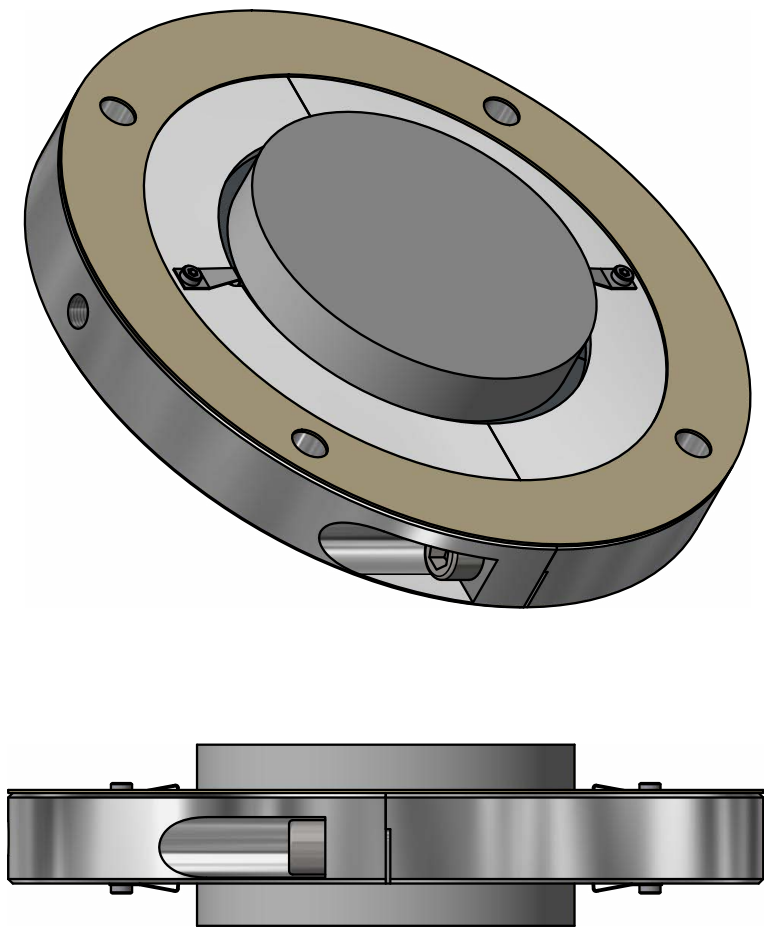

Exemplified dimensions (mm)

D	d2	PCD
50	170	140
80	200	170
100	220	190
110	230	200
120	240	210
150	270	240

D	d2	PCD
180	300	270
200	320	290
220	340	310
240	360	330
280	400	370
300	420	390

D	d2	PCD
340	460	430
400	520	490
460	580	550
500	620	590
600	720	690

Other shaft sizes (D), Imperial sizes as well as detailed drawings for project application available on request. We reserve the right to change data and dimension without prior notice.